

Remote Measurements & Research Company, LLC
214 Euclid Av.
Seattle WA 98122
michael@rmrco.com



RAD MANUAL, VERSION 9 (SW version 17c)

January 30, 2010

Contents

1	Introduction	2
2	Installation	3
3	Connections – Three Plug Configuration	5
4	Connections – Four Plug Configuration	7
5	Terminal Display & Commands	9
6	Case & Dome Thermistor Circuit	12
7	PIR Thermopile Circuit and Calibration Coefficients	13
8	PSP Thermopile Circuit and Calibration Coefficients	14
9	Calibration	15
10	Spot Checking Calibrations	18
11	Entering PSP and PIR Thermopile Calibrations	19
A	SCHEMATICS	20
B	PRINTED CIRCUIT BOARD	24
C	PRINTED CIRCUIT BOARD — TEST AND CALIBRATION	26
D	MATLAB Computation	28

RAD MANUAL, VERSION 9 (SW version 17c)

January 30, 2010

1 Introduction

The Radiometer Analog-to-Digital converter (RAD) provides a robust, highly accurate conversion from shortwave and longwave radiometers to a calibrated serial stream (EIA232 or 422) in physical units. The RAD is mounted near the sensors to avoid electronic noise issues. The overall uncertainty of the RAD (10 sec average) is less than a few tenths $W m^{-2}$ for either longwave or shortwave irradiance estimates. Thus RAD makes a negligible contribution to the overall measurement uncertainty.

A photograph of the RAD system mounted on the R/V PISCES in Jan 2010. The PSP (Precision Spectral Pyranometer) and PIR (Precision Infrared Radiometer) are mounted on the top plate with cables coming down to the RAD processor. An in-field splice to a customer supplied cable connected RAD to the ship computer system. In this installation the wires were 22 gauge and the cable length was 76 m (250') for power and RSS232, 9600 baud serial data.

INPUT:

Eppley PSP : thermopile voltage
 Eppley PIR : Thermopile voltage, Case thermistor,
 Dome Thermistor

OUTPUT: Shortwave irradiance ($W m^{-2}$)

Longwave irradiance ($W m^{-2}$)

Case temperature (C)

Dome temperature (C)

PIR thermopile voltage (mV)

Board temperature (C)

Input voltage (V)

OUTPUT SERIAL:

RS422 or RS-232 (9600 or 19200 bps, 8N1

NMEA comma separated fields.



By combining careful grounding, close proximity pre-amplification, microprocessor technology, and quality analog-to-digital electronics the RadADC eliminates noise interference and allows for long cables between radiometers and data acquisition computers.

2 Installation

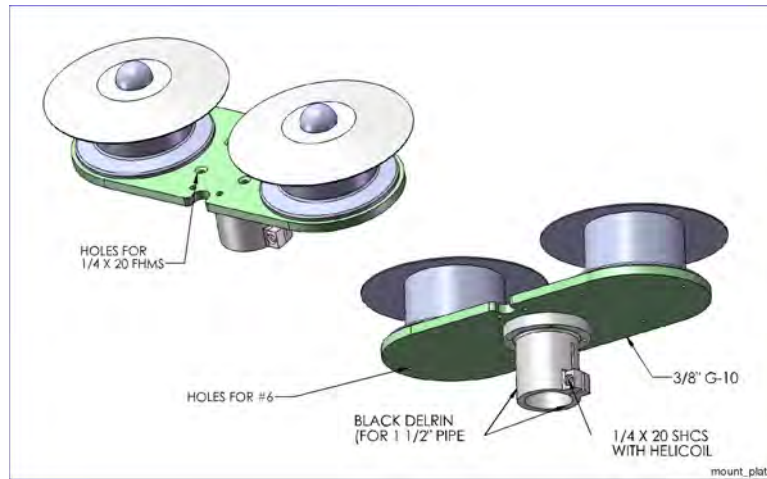

Figure 1: The PSP & PIR are mounted together on a AB plastic mount. The mounting pole is a standard 1.5" schedule 40 pipe (OD= 1.9").

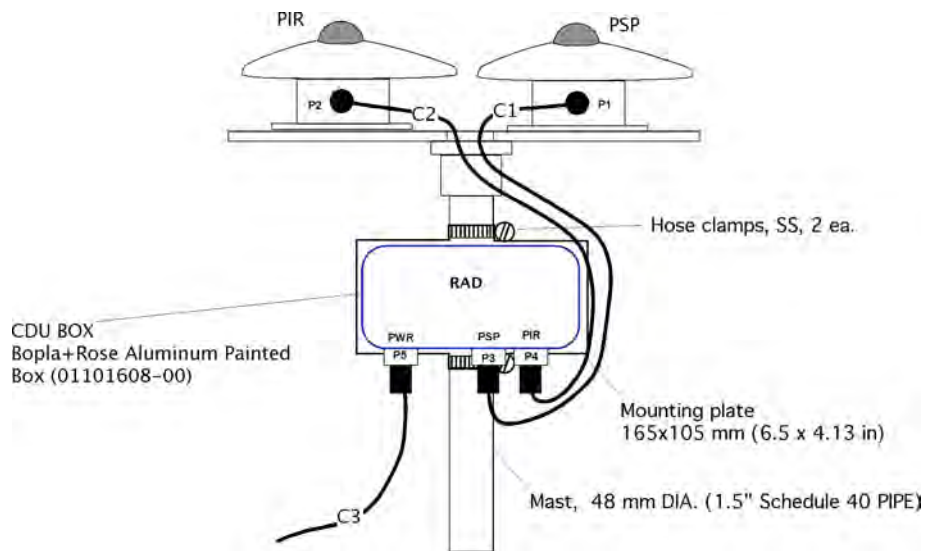

Figure 2: Installation sketch. The RAD Control Data Unit here is a three plug version with the power and 3-wire RS232 in the same plug.



Figure 3: Two different pipe mount fittings are available for 1.5" schedule 40/80 pipe. The top pipe mount bracket is made of heavy duty plastic. It's fittings are threaded with helicoil inserts. The bottom fitting is 6061-T6 aluminum with thermoplastic powder coat.

3 Connections – Three Plug Configuration

The 3-plug configuration makes for a more simple installation and is the preferred RAD configuration. The first models were 4-plug units and so connections for these units is included here. Connections for the RAD are relatively simple but one must be very careful about grounding and the power input. The serial output for RAD is either RS422 or RS232 as selected by the customer. See Figure 4 and be sure you identify each cable and understand the pin designations.

The serial configuration is

Parameter	Setting
Baud	19200 bps (settable)
Start & stop bits	1
Parity	none
Flow control	none

RS422 or RS232¹

The Impulse MCIL-6 power/communication connector is shown in Figure 4. The RS232 serial output and power connections are integrated into the same connector.

FUNCTION	PIN
TX+	4
TX-	5
RX+	6
RX-	3

In the RS232 configuration the Adam converter is removed and the Impulse connector (P6) is wired for a standard RS232 output. The serial parameters are the same as the above RS422.

Function	Impulse Pin	DB9-F DCE Pin	
Gnd	6	5	ground, common
TXD	5	3	output from host computer (DTE) DB9-male receptacle.
RXD	4	2	input to host computer (DTE) DB-9 male receptacle.

The standard nomenclature is used.

[Link: Serial connector wiring convention.](#)

¹American national standard ANSI/TIA/EIA-422-B (formerly RS-422) and its international equivalent ITU-T Recommendation V.11 (also known as X.27), are technical standards that specify the electrical characteristics of the balanced voltage digital interface circuit. RS422 provides for data transmission, using balanced or differential signaling, with unidirectional/non-reversible, terminated or non-terminated transmission lines, point to point, or multi-drop. Several key advantages offered by this standard include the differential receiver, a differential driver and data rates as high as 10 megabaud at 12 metres (40 ft). Maximum data rates are 10 Mbit/s at 12 m or 100 kbit/s at 1200 m. A common use of EIA-422 is for RS-232 extenders.

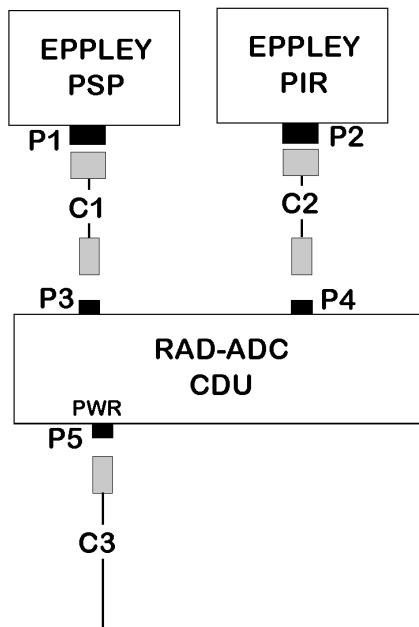

CABLES

- C1.** Three (3) conductor plus shield x 48". (Provided)
Amphenol PT06W-8-4S to Belden 8413 x 1.2m cable to Impulse MCIL-4-MP(w/LR).
- C2.** Seven (7) conductor plus shield x 48". (Provided)
Amphenol PT06W-12-10S to Belden 8427 x 1.2m cable to Impulse MCIL-8-MP(w/LR).
- C3.** Five (5) conductor plus shield x 48". (Provided)
Impulse MCIL-6-MP (w/LR) to Belden 8425 x 2 m to Junction box terminal block

PLUGS

- P1 Amphenol on the PSP.
- P2 Amphenol on the PIR.
- P3 Impulse MCBH-4-FS
- P4 Impulse MCBH-8 FS
- P5 Impulse MCBH-6-FS

CABLE C4 – RAD PWR/COMM

Impulse MCIL-6-MP(w/LR) to Belden 8425 x 0.6 m.
1-shield, 2-black, 3-white, 4-green, 5-red, 6-blue

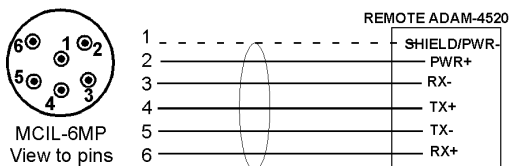

CABLE C2 – PIR RADIOMETER

Belden 8427 x 1.2m cable to Impulse MCIL-8-MP(w/LR)
1-shield, 2-black, 3-white, 4-brown, 5-green, 6-red, 7-yellow, 8-spares

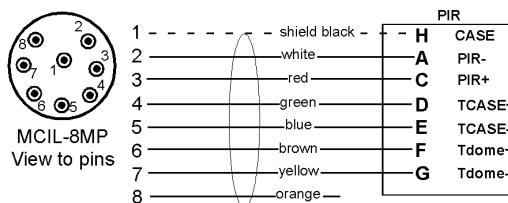

CABLE C3 – RS232

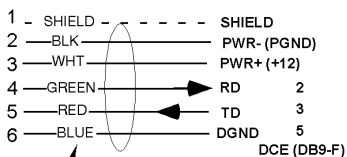

Standard cable colors
(ALWAYS CHECK)

CABLE C1 – PSP

Belden 8428 x 1.2m cable to Impulse MCIL-4-MP(w/LR).
1-shield, 2-black, 3-white, 4-spare

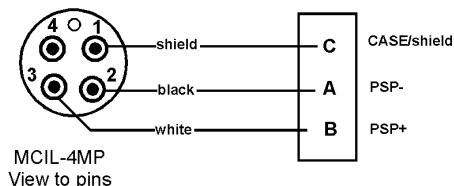

rad_wiring_3plug

Figure 4:

4 Connections – Four Plug Configuration

Connections for the RAD are relatively simple but one must be very careful about grounding and the power input. The serial output for RAD is either RS422 or RS323 as selected by the customer. See Figure 5 and be sure you identify each cable and understand the pin designations.

The serial configuration is

Parameter	Setting
Baud	19200 bps (settable)
Start & stop bits	1
Parity	none
Flow control	none

RS422

The Impulse MCIL-4 terminal connector is shown in Figure 5. An Adam-4520 is mounted with Velcro on the underside of the top of the RAD box. The RS422 connections to the Impulse “terminal” receptacle are

FUNCTION	PIN
TX+	4
TX-	5
RX+	6
RX-	3

RS232

In the RS232 configuration the Adam converter is removed and the Impulse connector (P6) is wired for a standard RS232 output. The serial parameters are the same as the above RS422.

Function	Impulse Pin	DB9-F DCE Pin	
Gnd	5	5	ground, common
TXD	3	2	output from host computer (DTE) DB9-male receptacle.
RXD	4	3	input to host computer (DTE) DB-9 male receptacle.

The standard nomenclature is used.

[Link: Serial connector wiring convention.](#)

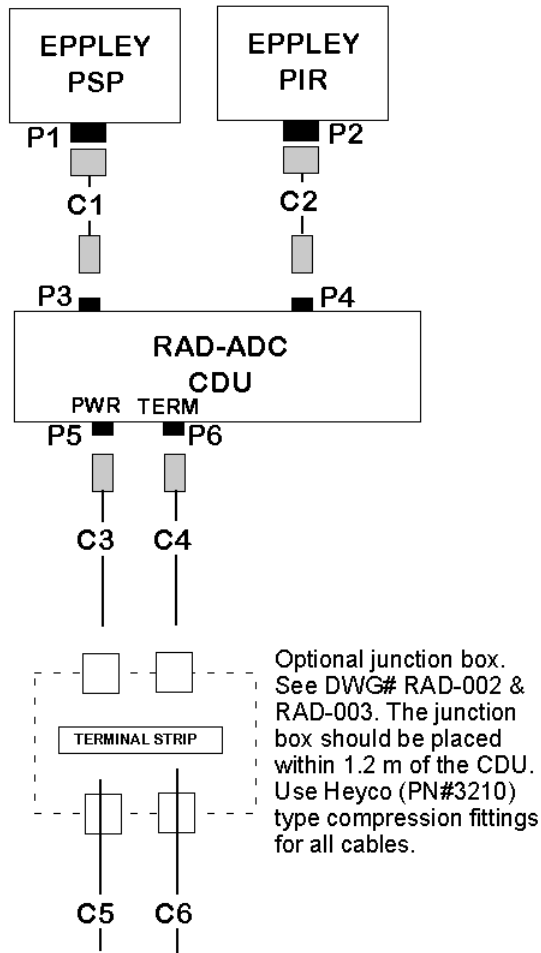

Optional junction box. See DWG# RAD-002 & RAD-003. The junction box should be placed within 1.2 m of the CDU. Use Heyco (PN#3210) type compression fittings for all cables.

DC Power 10.5-14 VDC 200 mA
 RS422 Serial 2 twisted pair with shield

CABLE C3 – RAD POWER
 Impulse MCIL-3-MP (w/LR) to Belden 8428 x 0.6 m to pigtail.
 1-shield, 2-black, 3-white

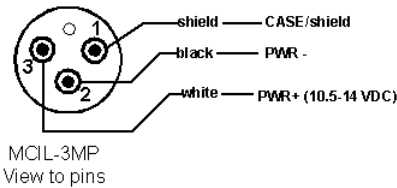

CABLE C1 – PSP
 Belden 8428 x 1.2m cable to Impulse MCIL-4-MP(w/LR).
 1-shield, 2-black, 3-white, 4-spare

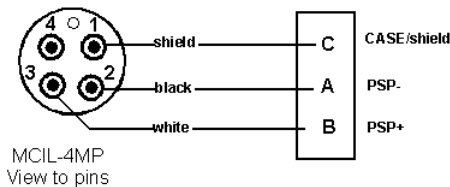

CABLES

- C1.** Three (3) conductor plus shield x 48". (Provided)
 Amphenol PT06W-8-4S to Belden 8428 x 1.2m cable to Impulse MCIL-4-MP(w/LR).
- C2.** Seven (7) conductor plus shield x 48". (Provided)
 Amphenol PT06W-12-10S to Belden 8427 x 1.2m cable to Impulse MCIL-8-MP(w/LR).
- C3.** Three (3) conductor plus shield x 48". (Provided)
 Impulse MCIL-3-MP (w/LR) to Belden ?? x 2 m to Junction box terminal block
- C4.** Five (5) conductor plus shield x 48". (Provided)
 Impulse MCIL-3-MP(w/LR) to Belden ?? x 2m to Junction box terminal block
- C5.** Three (3) conductor plus shield. (Aepco supplied)
 +DC, -DC, shield
- C6.** Four (4) conductor plus shield. (Aepco supplied)
 +RD,-RD,+TD,-TD,shield

PLUGS

- P1** Amphenol on the PSP.
- P2** Amphenol on the PIR.
- P3** Impulse MCBH-4-FS
- P4** Impulse MCBH-8 FS
- P5** Impulse MCBH-3-FS
- P6** Impulse MCBH-6-FS

CABLE C2 – PIR RADIOMETER

Belden 8427 x 1.2m cable to Impulse MCIL-8-MP(w/LR)
 1-shield, 2-black, 3-white, 4-brown, 5-green, 6-red, 7-yellow, 8-spare

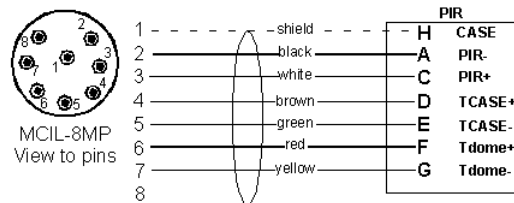

CABLE C4 – RAD TERMINAL (RS422)

Impulse MCIL-6-MP(w/LR) to Belden 8425 x 0.6 m.
 1-shield, 2-blue, 3-red, 4-black, 5-white, 6-green

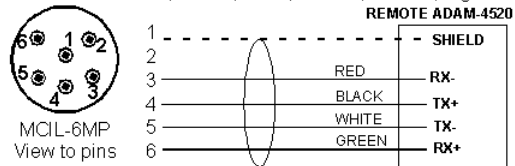

CABLE C4 – RAD TERMINAL (RS232)

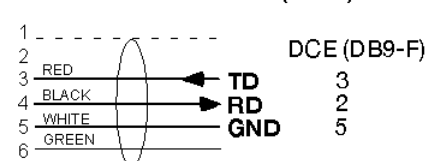

Figure 5:

5 Terminal Display & Commands

RAD start up display. RAD sends the following display on power up. After this sign-on display RAD enters the data collection mode.

```

RAD SIGN ON MESSAGE

*** RADIOMETER ANALOG TO DIGITAL INTERFACE (RAD) ***
Software Version 1.17c, 2009,03,24
Digital Interface Board - Rev C. Feb 2009
Current EEPROM values:
Identifier Header= $WIR02
PSP Coeff= 8.00E-6
PIR Coeff= 4.00E-6
Interval Time (secs)= 10
Cmax= 2048
Reference Resistor Case= 32958.0
Reference Resistor Dome= 33010.0
Vtherm= 4.0940, Vadc= 4.0940
PIR ADC Offset= 2.29 mv
PIR ADC Gain= 836.34
PSP ADC Offset= 4.16 mv
PSP ADC Gain= 118.02
    
```

Run Time Output The output data lines are written at the end of each averaging cycle. The analog-to-digital converter is read each 0.1 sec throughout the averaging period. Thus a 10-sec average will be an average of

TYPICAL OUTPUT										
ID	DATE	TIME	#	PIR	LW	TCASE	TDOME	SW	T-AVR	BATT

\$WIR02	09/03/25	19:12:00	76,	-5.1,	447.34,	25.03,	24.98,	998.74,	28.4,	11.4
\$WIR02	09/03/25	19:12:10	175,	-5.4,	446.67,	25.02,	24.99,	998.97,	28.5,	11.4
...										

The date and time are read from the real time clock at the end of the averaging cycle, at the time of print out.

During operation, the header can be printed by entering H at the keyboard.

Output Variables

ID	NMEA-style tag. Set with 'A' command from menu.	—
DATE TIME	yy/MM/dd, hh:mm:ss. Set with 'T' command from menu.	GMT
#	the number of samples that went into the averages.	—
PIR	the average voltage from the PIR thermopile.	millivolts
LW	the computed longwave downwelling irradiance	$W m^{-2}$.
TCASE	the PIR case temperature	$^{\circ}C$.
TDOME	the PIR dome temperature	$^{\circ}C$.
SW	the computed shortwave downwelling irradiance.	$W m^{-2}$.
T-AVR	the temperature on the circuit board.	$^{\circ}C$.
BATT	the battery voltage after the input diode drop	volts.

Measurement Error. Analog-to-voltage conversion noise is reduced significantly by averaging. The ADC sampling noise is typically 2 mV for the PSP circuit and 5 mV for the PIR circuit. The amplification gains for these two signals are approximately 120 and 840 respectively. In a 10-sec averaging period the sample count (“#”) is about 175. The sensor gain for the two radiometers are approximately $8 \mu\text{V}/\text{W m}^{-2}$ and $3 \mu\text{V}/\text{W m}^{-2}$ respectively. Errors for the radiometers are

$$\text{PSP error} = 2 \text{ mv}/120/\sqrt{175} = 1.2 \mu\text{V} \quad (1)$$

$$\text{PIR error} = 5 \text{ mv}/840/\sqrt{175} = 0.44 \mu\text{V} \quad (2)$$

$$(3)$$

The measurement uncertainty (10-sec average) are typically 0.15 W m^{-2} for longwave or shortwave output.

Main Menu.

To stop data collection and go to the command menu, enter “T” (case sensitive). A prompt `Command?>` indicates the unit is in the command mode. Enter ? to see a menu of available commands. EEPROM variables are shown in parentheses.

Typically one can make changes to existing eeprom variables or to the time by entering the designated letter and following the instructions.

```

MAIN MENU

WIRO2 BOARD (REV B) VERSION: 1.17c, VERSION DATE: 2009,03,24
Digital Interface Board - Rev C. Feb 2009
Current datetime: 090325,191216
-----USER ENTER INFORMATION-----
'k' -->Set PSP coefficient (8.00E-6 v/(W/m^2))
'K' -->Set PIR coefficient (4.00E-6 v/(W/m^2))
'A' -->Change Identifier String. (02)
-----RAD CALIBRATION DATA-----
'g' -->Set PSP amplifier gain value. (118.0)
'o' -->Set PSP amplifier offset, mv. (4.2 mv)
'G' -->Set PIR amplifier gain value. (836.3)
'O' -->Set PIR amplifier offset, mv. (2.3 mv)
'C' -->Set Case 32958.0 ohms, -8.574e-5, 9.372e-2, -3.255e1
'D' -->Set Dome 33010.0 ohms, -3.648e-5, 3.990e-2, -1.494e1
'V' -->Set Thermistor Reference & ADC Reference Voltage (4.1 mV).
Cmax = 2048 (fixed)
-----DATE & TIME SETTING-----
'T' -->Set the date/time.
-----TIMING SETTING-----
'L' -->Set averaging time in seconds. (10)
-----OTHER-----
'S' -->Sample 12 bit A to D.
'r' --> toggle test mode.
'X' -->Exit this menu, return to operation.
=====
Command?>

```

The “USER ENTER INFORMATION” can be set in the field by the user. The radiometer coefficients are provided with the radiometers. The identifier string is a two character string at the end of the NMEA identifier. By NMEA 0183 convention, the record identifier has five characters. The first two characters are “WI” meaning weather instruments. The third character has been assigned to be “R” for radiation. The final two characters

are user assigned via the user menu. This can be instrument serial number, e.g. “02”. Other options might be the experiment number.

The “RAD CALIBRATION DATA” variables are set up during laboratory calibration with precision references. These should not be changed in the field.

Typical Menu Setup Example.

If a new software hex file is uploaded to the RAD the entire list of parameters must be loaded into the EEPROM. The list below is used. Note that a special list is provided for each instrument and for each calibration. The list below is only an example.

SET FOR EACH APPLICATION.

L	10	Averaging time in seconds.
k	7.94e-6	PSP radiometer coefficient.
K	3.94e-6	PIR radiometer coefficient.
A	02	NMEA tag, final two characters.
T	090324123400	yyMMddhhmmss date-time set real time clock.
V	4.094	Reference voltage (TP16).

SET FROM LAB CALIBRATION

g	118.02	PSP amplifier gain.
o	4.16	PSP amplifier output offset.
G	836.34	PIR amplifier gain.
O	2.29	PSP amplifier output offset.
C 0	32958	Case thermistor circuit reference resistor
C 1	-8.574e-5	Case ADC correction parameter 1
C 2	9.372e-2	Case ADC correction parameter 2
C 3	-32.55	Case ADC correction parameter 3
D 0	33010	Dome thermistor circuit reference resistor.
D 1	-3.648e-5	Dome ADC correction parameter 1
D 2	3.990e-2	Dome ADC correction parameter 2
D 3	-14.94	Dome ADC correction parameter 3

6 Case & Dome Thermistor Circuit

The PIR has a case and dome temperature thermistor. Both thermistors are made by YSI, and are of type 44031 (pdf). These are $\pm 0.1^\circ\text{C}$ interchangeable.

See figure A for the thermistor circuit. The Max186 adc circuit has a reference voltage output, V_{ref} , which is used in the thermistor circuits. The Max186 is operated in the bi-polar mode (mode = 0) giving it an input range of -2048 to 2047 mV. The reference resistors are approximately 33K ohms. The equation for the thermistor resistance independent of the reference voltage and is given by:

$$R_t = R_{ref} \frac{c}{(C_{max} - c)}$$

where R_{ref} is the reference resistor which is connected to V_{ref} . c is the output count from the Max186 divided by 2, and C_{max} is the maximum count of 4096. Note that c is corrected for the case and dome circuits as described in the section below.

The thermistor resistance is converted to temperature using the Steinhart-Hart equation:

$$x = C_0 + C_1\rho + C_2\rho^3$$

$$T = \frac{1}{x} - 273.15$$

where C (3×1) are the Steinhart-Hart coefficients, $[C] = [1.025579e - 03, 2.397338e - 04, 1.542038e - 07]$, and ρ is the log of the computed thermistor resistance, $\log(R_t)$.

Finally a small self-heating correction is subtracted as recommended by the manufacturer:

$$T' = T - \frac{P_t}{.004}$$

where

$$P_t = i^2 R_t$$

and

$$i = \frac{V_{adc} - v_t}{R_{ref}}$$

CASE AND DOME TEMPERATURE CALIBRATION VALUES

Three metal-film thermistors were selected and measured to high precision.

R_{cal}	v_t	T ($^\circ\text{C}$)
5621	0.5961	39.861
9991	0.9519	25.022
14966	1.2798	15.208

Correction of the Thermistor ADC Conversion

The value ADC count, c , is a corrected value. If the actual case and dome ADC counts are c'_c and c'_d , a quadratic correction yields

$$c_c = c_1 c_c'^2 + c_2 c_c' + c_3 \quad (4)$$

$$c_d = d_1 c_d'^2 + d_2 c_d' + d_3 \quad (5)$$

$$(6)$$

The parameters $c_c(i)$ and $c_d(i)$, $i = 1, 2, 3$ are determined during calibration and set in EEPROM. After application of this calibration correction, the computed temperatures agree with the standard thermistor table to better than 0.02°C .

7 PIR Thermopile Circuit and Calibration Coefficients

The PIR thermopile output voltage, v_{pir} , is related to the IR irradiance onto the thermopile under the glass dome. The PIR voltage is very small, typically a few microvolts, and must be multiplied in a preamplifier before being converted to a digital sample. The RAD microprocessor samples the ADC at approximately 70 Hz so a ten second output time will average approximately 670 instantaneous ADC samples. The ADC output is related to the PIR irradiance by the equation

$$\mathcal{R}_p = \frac{v_{adc} - v_{off}}{1000 G K}$$

where \mathcal{R}_p is the thermopile irradiance, K is the radiometer calibration coefficient, v_{adc} is the output of the ADC in millivolts, v_{off} is the amplifier offset in millivolts which should be very small, and G is the gain in the preamplifier circuit. A typical values for K_{pir} is 3×10^{-6} volts per W m^{-2} .

The analog-to-digital circuit uses a Max186 ADC to convert preamplifier output voltage to an adc count by the equation

$$c = C_{max} \frac{v_{in}}{v_{ref}}$$

where where v_{in} is the input voltage, and C_{max} is the ADC maximum count corresponding to an input of V_{ref} . For a 12-bit ADC, $C_{max} = 4095$ and for the Max186, $v_{ref} = 4.095$ volts. Therefore the output count is almost exactly the input in mV, $v_{adc} = c = v_{in}$. We refer to v_{adc} as the measured ADC count in mV.

As seen in figure A, the output of the PIR thermopile is treated as a differential voltage into an instrumentation amplifier (Burr-Brown INA2128). The resistor R5 determines the gain of the amplifier by the equation $G = 1 + 50000/R_G$ where where R_G is the gain resistor, For the PIR thermopile circuit, $R_G = R_5 \approx 62$ ohms and the amplifier gain would be approximately 807.45.

Combining the above equations gives:

$$v_{pir} = \frac{(v_{adc} - v_{off})}{1000 G}$$

where $v_{adc} = c$ is the output of the ADC and v_{off} is the offset.

Calibration of the thermopile circuit is made by applying small voltages, v_{pir} , to the PIR input connector and measuring the output counts, v_{adc} . The ADC instantaneous output is available with the 'S' command from the menu. After several samples press 'enter' and the mean and standard deviation for each channel is computed. A straight line fit is then used to determine G and v_{off} . G and v_{off} can be set in the menu with the 'G' and 'O' options.

The Albrecht-Cox relationship gives the downwelling IR irradiance

$$\mathcal{R}_{LW\downarrow} = \mathcal{R}_{pir} + \sigma T_C^4 - k \sigma (T_D^4 - T_C^4)$$

where σ is the Stefan Boltzmann constant ($5.6704 \times 10^{-8} \text{ W m}^{-2} \text{ K}^{-4}$), T_C is the case temperature in °K, T_d is the dome temperature in °K, and k is a constant generally set to 4.

The output data line provides the average value of $\mathcal{R}_{LW\downarrow}$ and the last measured instantaneous value for v_{adc} . The v_{adc} value will be somewhat noisy because it is an instantaneous reading. It is provided for purposes of quality assurance. It is best measured using the 'S' command as described above.

There are a few simple tests by which one can evaluate the PIR performance. When a heat source is placed above the PIR, the thermopile signal should go positive. For example, put your hand over the dome – creating a 37°C blackbody. The output irradiance measured should be around 525 W m^{-2} . Next, (carefully) place something frozen from the freezer above the dome, creating a 0°C source and the irradiance should be approximately 315 W m^{-2} .

8 PSP Thermopile Circuit and Calibration Coefficients

The PSP gain (provided from the manufacturer) is given by the equation

$$v_{psp} = R_{SW\downarrow} k$$

where $R_{SW\downarrow}$ is the total downwelling shortwave irradiance, and k is the PSP gain. Typically $k \approx 8 \times 10^{-6}$ volts per W m^{-2} .

As above, the signal v_{psp} is amplified in the differential INA2128 and converted to an ADC count in the Max186. The combined output has a form of

$$c = g v_i + o$$

where g is the combined gain for the amplifier and the ADC converter, and o is the offset in counts. For the PSP circuit, $g \approx 125$. After trimming the circuit with zero input, $o \approx 2$ mV.

The precision ADC provides its own reference voltage so the $C_{max} = 4096$ and $V_{ref} \approx 4096$ mv. After electronic calibration, the shortwave irradiance is given by

$$R_{SW\downarrow} = \left(\frac{c - o}{1000 g} \right) \frac{1}{k}$$

where the divisor of 1000 converts mV to V to agree with the units of k .

To determine the overall electronic gain one must make have at least two outputs from the instrument. Measure the out put of the PSP using a good voltmeter. Choose a time near midday when there are minimal clouds and there are no clouds covering the sun. Let v_1 be the measured voltage from the PSP. Using the menu, and the S command, let c_1 be the count with the same irradiance. A small time lapse is not a major source of error as long as the clouds are minimal. Next cover the PSP and measure the dark current ADC count (mV) with the S command. The count during dark conditions are c_0 and v_0 . The system gain equation is then

$$g = \left(\frac{c_1 - c_0}{v_1 - v_0} \right)$$

generally the offsets are very low and can be neglected in the evaluation of g . As an alternative, a precision voltage source such as the Julie Lab “Volt-a-vider” can be used to fit a straight line to the gain equation. A field determination of c_0 is usually a last task after installation.

²**Nighttime offsets** have been a major issues in the radiation community. A PSP will typically give -4 W m^{-2} at nighttime from the thermal differences in the PSP thermopile. (It is interesting to note that with a ventilator the output will go down to -6 W m^{-2} .) The radiation community has many different means to handle this offset. Generally the scientific community set the nighttime values, from sunset to sunrise, to zero during post processing. The daytime values are reported in realtime with $v_0 = 0$ and $c_0 = 0$. Then $M = c_1/v_1$. A final shortware irradiance is computed during post processing.

²Personal communication with John Hickey, The Eppley Labs.

9 Calibration

Connections to the RAD circuit board are shown in Figure 6 below. The plugs are **Tyco Ampmodu connectors**. Two test plugs are used for checking and calibrating the board external to the weatherproof package. One plug provides power to the board and connects to a serial DTE computer. The second plug provides the four needed input signals: PSP, PIR, Tcase, and Tdome.

The dashed boxes show the default test setup. With these the output PSP and PIR values (Section 5) will be near zero and the case and dome temperatures will be 25 °C. The 610 ohm resistors simulate the output resistance of the two thermopiles. They should be left in the circuit during calibration.

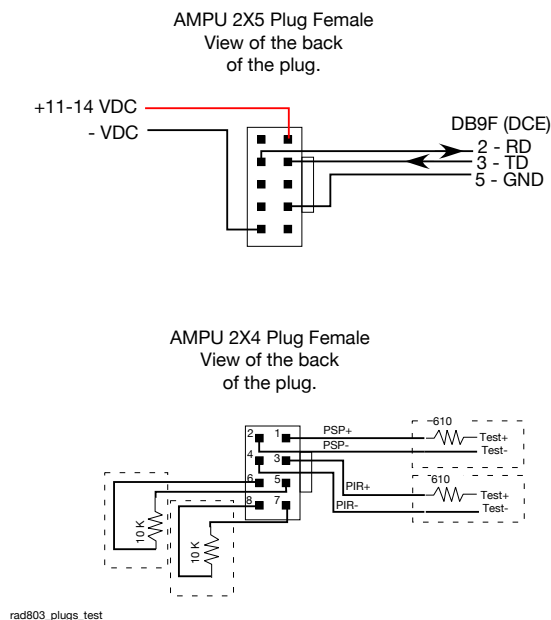

Figure 6: Connections for calibration of the RAD. Simple test cables with Ampmodu plugs can be plugged directly into the RAD circuit board. Voltage inputs range from ± 2 millivolts. A set of precision resistors are used to simulate the case and dome thermistors.

The RAD amplifiers are calibrated by using a precision millivolt reference source and a set of precision resistors to calibrate the thermistor divider circuit. The PSP thermopile calibration coefficients (g & o) and the PIR thermopile coefficients (G & O) are computed by fitting a straight line to a set of input voltages. The thermistor circuit calibration requires four coefficients, each for case and dome thermistors, that are derived from a set of precision resistances. The output from a calibration is shown in the text beginning on the next page.

The full set of EEPROM coefficients is shown at the end of the calibration document. Each of these is set in the RAD as part of a full calibration. RAD is a relatively new instrument. Hence it is recommended that it be calibrated on an annual basis. We hope that with experience we will find that the amplifier calibrations will be much more stable so calibration intervals can be extended to two or even three years.

```

=====
CALIBRATION RESULTS FOR RAD SN 206.  CAL DATE = 2010-01-26.
RUN TIME: 20100126,181909
setupfile: /Users/rmr/instruments/RAD/Cal/206_MossLanding/radcal_setup_206_100126.txt
SN: 206
calpath: /Users/rmr/instruments/RAD/Cal/206_MossLanding
caldate: 100126
Reference voltage = 4093.0 millivolts (TP16)
    
```

```

PSPCAL
-1.0, -120.40, 1.4
-0.5, -60.70, 1.8
-0.1, -13.15, 2.0
0.0, -0.71, 2.4
0.1, 11.24, 2.2
0.2, 22.58, 1.5
0.5, 58.48, 2.2
1.0, 117.75, 2.7
2.0, 237.20, 2.6
4.0, 474.70, 2.2
8.0, 950.08, 1.0
    
```

```

PIRCAL
-2.0, -1682.80, 16.5
-1.0, -843.00, 11.0
-0.8, -674.00, 18.0
-0.4, -340.00, 12.0
-0.2, -172.50, 18.0
0.0, -6.00, 12.0
0.2, 165.40, 12.0
0.4, 332.00, 12.0
0.8, 663.00, 13.0
1.0, 835.00, 12.0
    
```

```

caseR
5600, 0.594, 594.80, 0.70, 39.92
10000, 0.952, 950.33, 0.60, 25.07
14974, 1.278, 1264.06, 0.70, 15.63
    
```

```

domeR
5621, 0.595, 595.50, 0.70, 40.00
10000, 0.953, 954.39, 0.80, 25.05
14974, 1.279, 1276.80, 0.40, 15.39
    
```

```

==== CASE TEMPERATURE =====
Case Rref = 31260, Rref based on measurements of v_t = 32987. Error = -5.5
Case fit : -4.806e-05 6.731e-02 -2.223e+01
    
```

```

CASE THERMISTOR MILLIVOLTS
Meas      ADC      ADC-Corrected
594.0     594.8     594.0
952.0     950.3     952.0
1278.0    1264.1    1278.0
    
```

```

CASE THERMISTOR OHMS
CalR      Meas      ADC  ADC-corrected
5600      5307      5315 5307
10000     9475      9453 9475
14974     14192     13968 14192
    
```

```

CASE THERMISTOR DEG C
CalR      Meas      ADC  ADC-correc  Tout
39.96     41.41     41.37 41.41 39.92
25.00     26.34     26.40 26.34 25.07
15.24     16.51     16.88 16.51 15.63
    
```

```

==== DOME TEMPERATURE =====
Dome Rref = 31200, Rref based on measurements of v_t = 32979. Error = -5.7
    
```

Dome fit : -1.998e-05, 3.345e-02, -1.233e+01

DOME THERMISTOR MILLIVOLTS

Meas	ADC	ADC-Corrected
595.0	595.5	595.0
953.0	954.4	953.0
1279.0	1276.8	1279.0

DOME THERMISTOR OHMS

CalR	Meas	ADC	ADC-corrected
5621	5317	5322	5317
10000	9488	9506	9488
14974	14208	14173	14208

DOME THERMISTOR DEG C

CalR	Meas	ADC	ADC-correc	Tout
39.86	41.36	41.34	41.36	40.00
25.00	26.31	26.26	26.31	25.05
15.24	16.48	16.54	16.48	15.39

==== PSP THERMOPILE CIRCUIT =====
 PSP Calibration Gain (g) = 118.92, Offset (o) = -1.0 millivolts

==== PIR THERMOPILE CIRCUIT =====
 PIR Calibration Gain (g) = 838.60, Offset (o) = -4.6 millivolts

=====
 RAD SETUP COMMANDS
 L : 10
 k : 8.14e-6 (Eppley PSP cal)
 K : 4.27e-6 (Eppley PIR cal)
 A : 06 (Experiment or SN, 2 digits)
 V : 4093
 C 0 : 32987
 C 1 : -4.806e-05
 C 2 : 6.731e-02
 C 3 : -2.223e+01
 D 0 : 32979
 D 1 : -1.998e-05
 D 2 : 3.345e-02
 D 3 : -1.233e+01
 g : 118.92
 o : -1.05
 G : 838.60
 O : -4.57

10 Spot Checking Calibrations

A simple circuit can be used to spot check the RAD calibration.

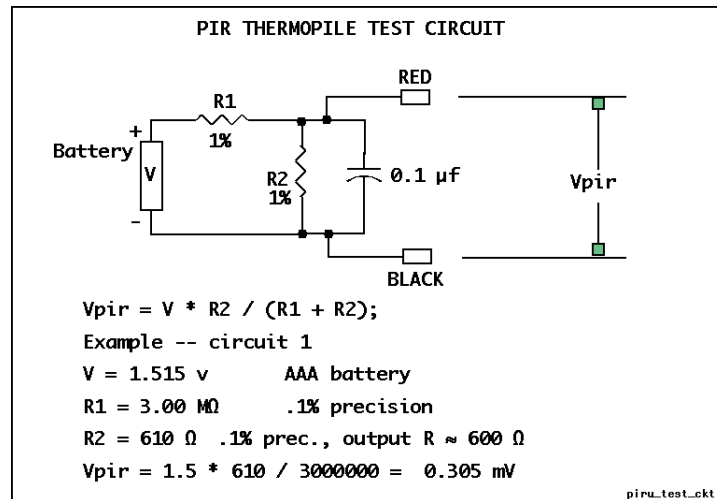

Figure 7: A simple spot calibration circuit diagram. The output of this circuit (V_{pir}) will depend on the battery voltage but will be on the order of 0.3 mV. This circuit can be plugged into the PSP or PIR Amphenol connectors for a spot measurement to confirm operation.

11 Entering PSP and PIR Thermopile Calibrations

The RAD can be set for any different PSP or PIR by setting the calibration coefficients in the RAD menu. The radiometer calibration coefficients are determined by the manufacturer or by an equivalent facility. The calibration coefficient is a single number. The PSP coefficient is approximately 9×10^{-6} volts/ W m^{-2} . The calibration coefficient for the PIR is about 3×10^{-6} volts/ W m^{-2} . Enter the menu as described in this manual. Enter a 'k' to change the PSP coefficient. Enter a 'K' to change the PIR coefficient. Be sure to enter the coefficients with the 'e' designator for powers of ten. For example 'k' might be entered as '8.45e-6' and 'K' might be '3.23e-6'.

A SCHEMATICS

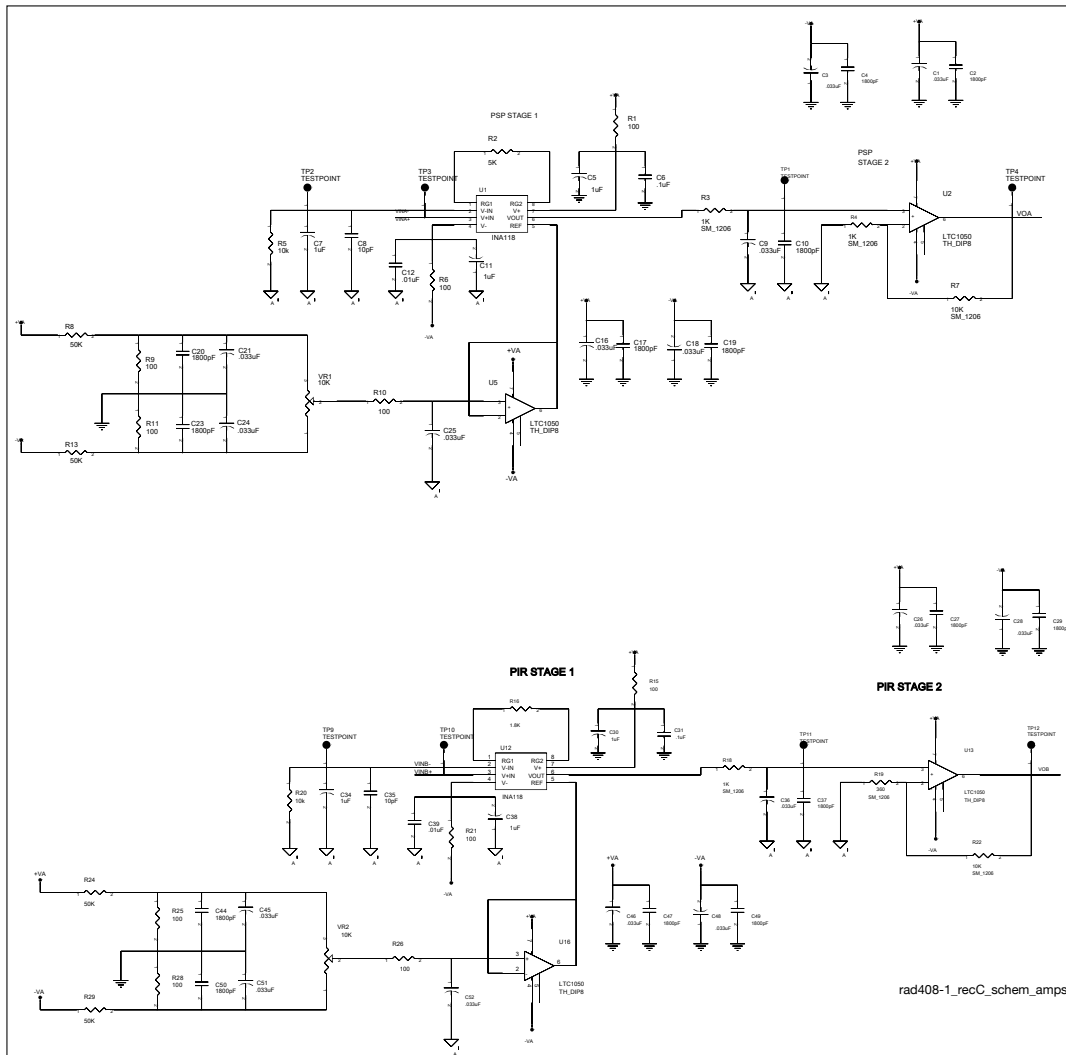

Figure 8: RAD schematic, analog-to-digital circuits.

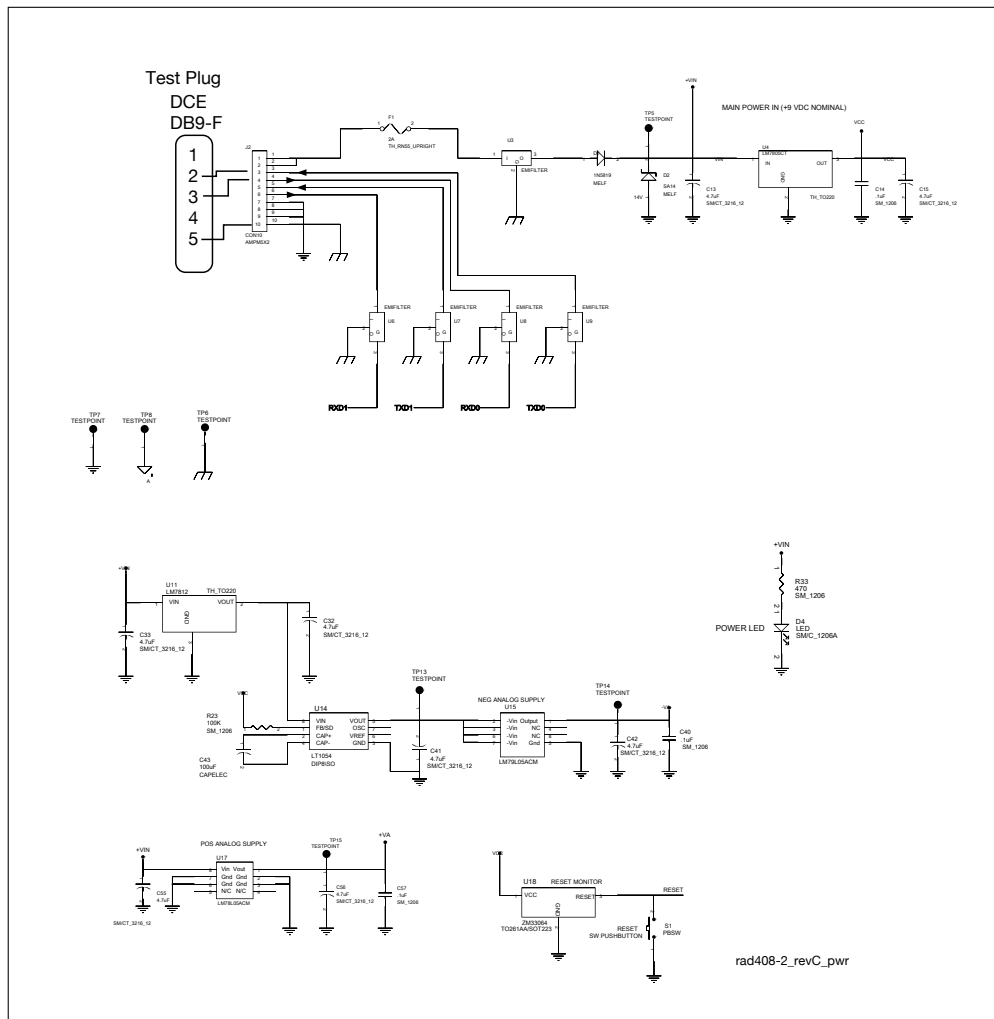

Figure 9: RAD schematic, analog-to-digital circuits.

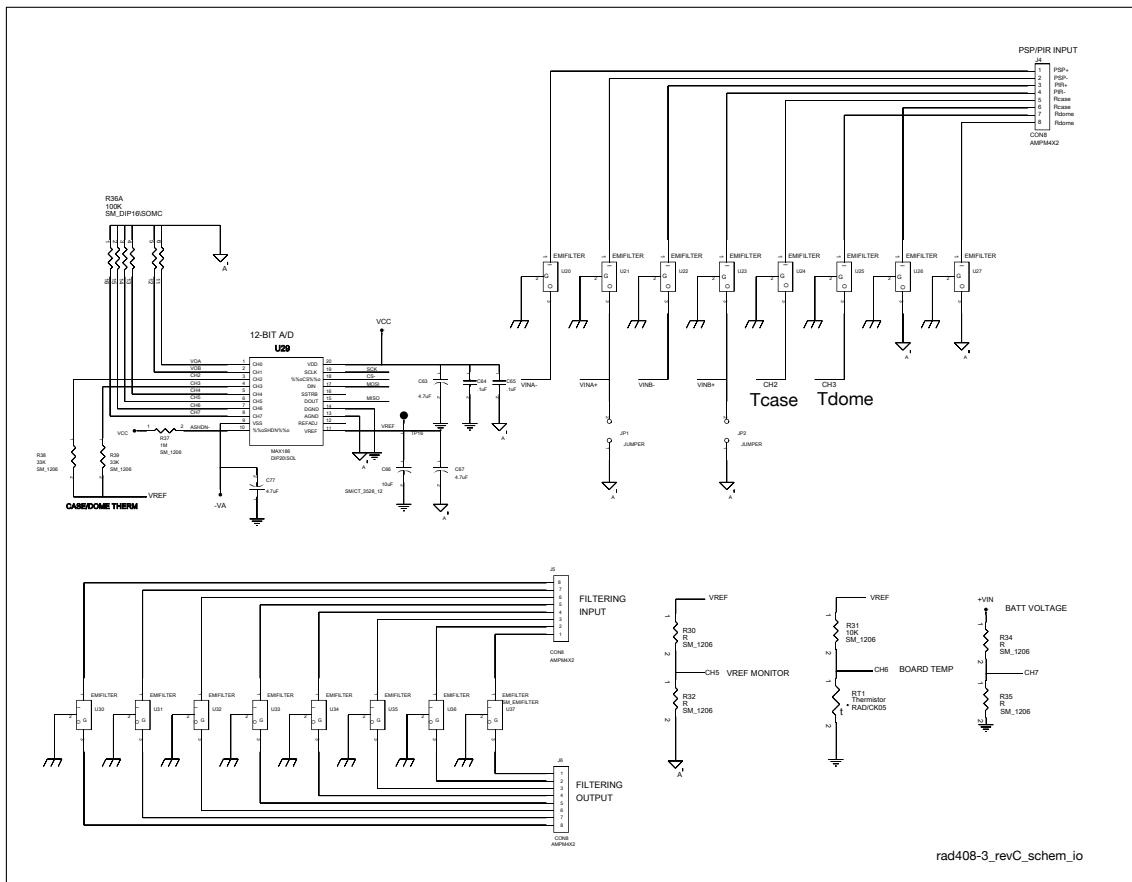

Figure 10: RAD schematic, analog-to-digital circuits.

B PRINTED CIRCUIT BOARD

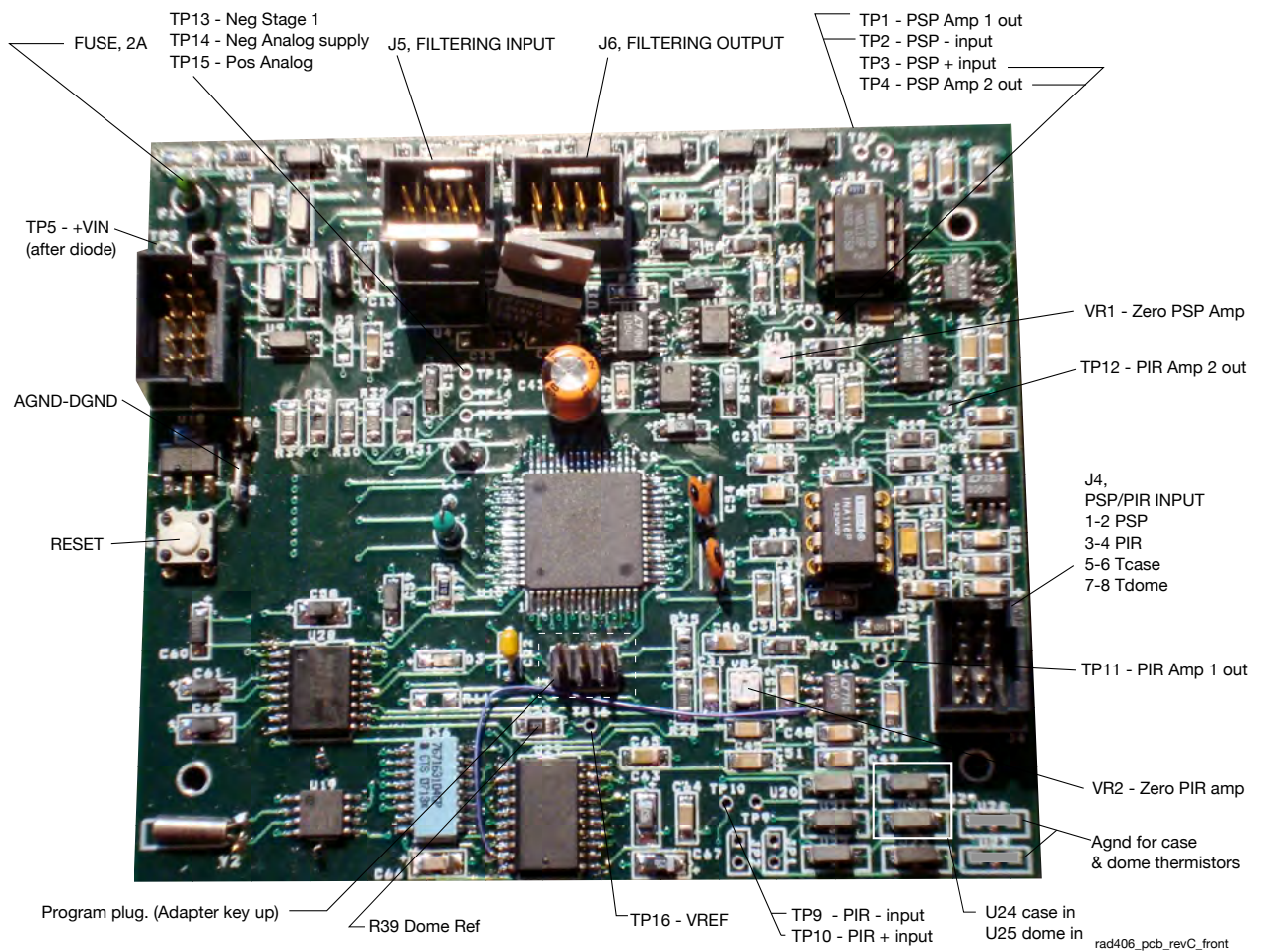

Figure 12: RAD printed circuit board, front view

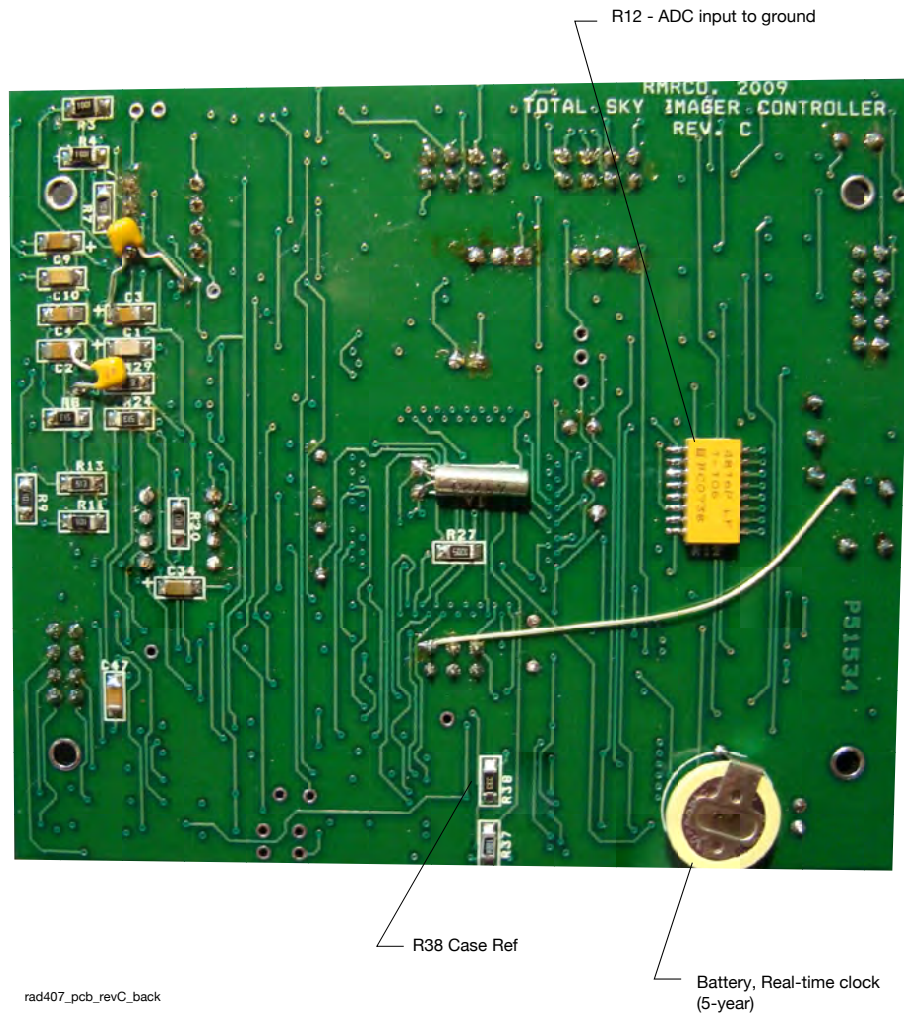

Figure 13: RAD printed circuit board, front view.

C MATLAB Computation

```

function [lw, e, C_c, C_d] = RadTcTd2LW(v, G, O, K, tc, td, k);
%
%function [lw, e, C_c, C_d] = RadTcTd2LW(mv, G, O, K, tc, td);
%-----
%
%input
% v = Rad ADC output in mV (typ -300 mv)
% G = preamp gain (typ 825)
% O = preamp offset (typ < 20 mv)
% K = PIR calibration (typ 3.9e-6 V/W/m^2)
% tc = case degC
% td = dome degC
% no arguments ==> test mode
%output
% lw = corrected longwave flux, W/m^2
% e = thermopile irradiance W/m^2
% C_c C_d = corrections for case and dome, w/m^2
%-----
%000928 changes eps to 0.98 per {fairall98}
%010323 back to 1.0 per Fairall
%100113 adapted from PirTcTd2LW.m

k=4;

% compute thermopile radiation
e = (v-O)/G/1000/K;

% THE CORRECTION IS BASED ON THE TEMPERATURES ONLY
Tc = tc+273.15;
Td = td+273.15;

eps = 1;
sigma = 5.67e-8;
C_c = eps .* sigma .* Tc .^ 4;
C_d = - k .* sigma .* (Td .^ 4 - Tc .^ 4);

lw = e + C_c + C_d;
return

```